

Mechanical Gauges

Bourdon Vacuum Gauges

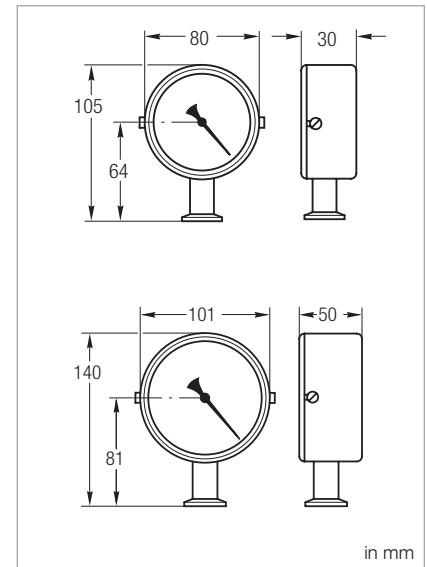

Rugged relative pressure vacuum gauges based on the Bourdon principle covering the pressure range from 1 to 1020 mbar (0.75 to 765 Torr).



Dimensional drawing for the BOURDONVAC A (top) and the BOURDONVAC C (bottom)

Advantages to the User

- Highly reliable, rugged, insensitive to vibrations
- Linear readout, independent of the type of gas
- Excellent media compatibility owing to the stainless steel movement (BOURDONVAC C)
- IP 54 protection (BOURDONVAC C)

Typical Applications

- Vacuum distillation
- Drying processes
- Vacuum conveying systems

Technical Data

BOURDONVAC A

BOURDONVAC C

Measurement range	mbar (Torr)	1 to 1020 (0.75 to 765)	1 to 1020 (0.75 to 765)
Measurement uncertainty	% FS	1	1
Class 1 (EN 837)	% FS	1	1
Overload range (abs. briefly)	bar	1.5	1.3
Storage temperature range	°C	-25 to +60	-25 to +60
Nominal temperature range	°C	+10 to +60	+10 to +100 (max.)
Flange connection	DN	16 ISO-KF	16 ISO-KF
Length of scale	mm	207	188
Diameter	mm	80	101
Overall height	mm	105	140
Weight	kg (lbs)	0.25 (0.55)	0.5 (1.10)
Leak tightness	mbar x l/s	1×10^{-8}	1×10^{-8}
Materials in contact with the medium		Nickel plated standard steel, bronze, soft solder	Stainless steel 1.4404

Ordering Information

BOURDONVAC A

BOURDONVAC C

	Part No.	Part No.
Bourdon vacuum gauge	160 40	161 20